

PH60K10 PIPE LIFTER

- REPLACEABLE URETHANE PADS
- CAN HANDLE UP TO 10' SECTIONS
- DESIGNED AND CONSTRUCTED IN ACCORDANCE WITH ASME B.30.20

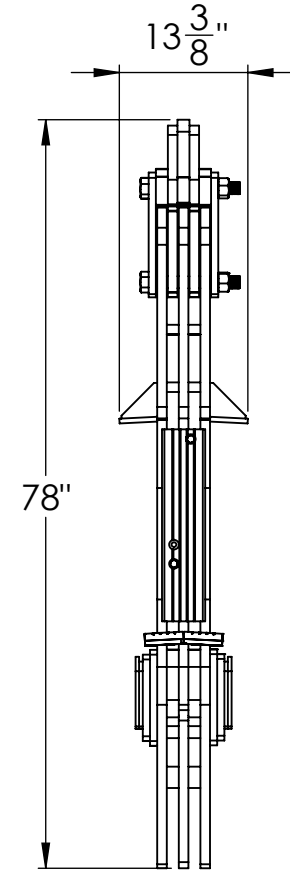

DRAWN BY:
J.Mastruserio
DATE:
10/22/2020

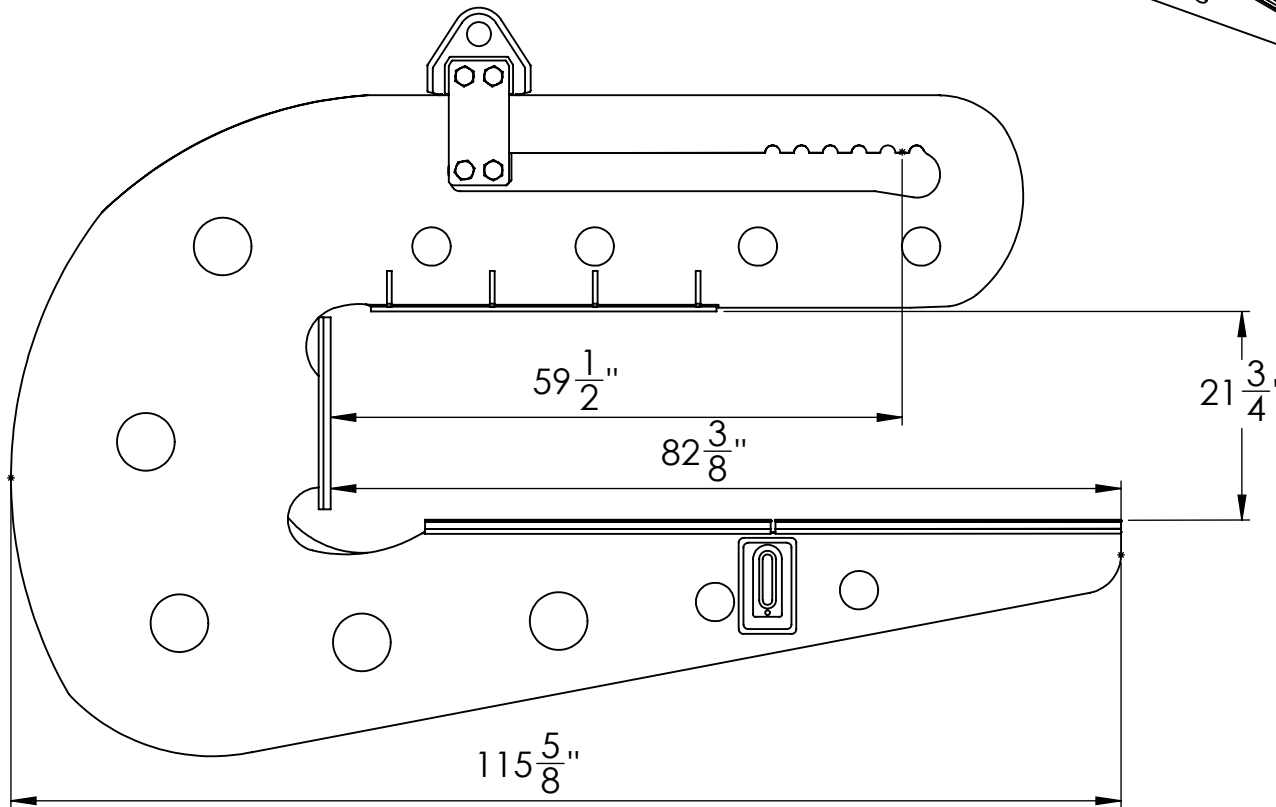
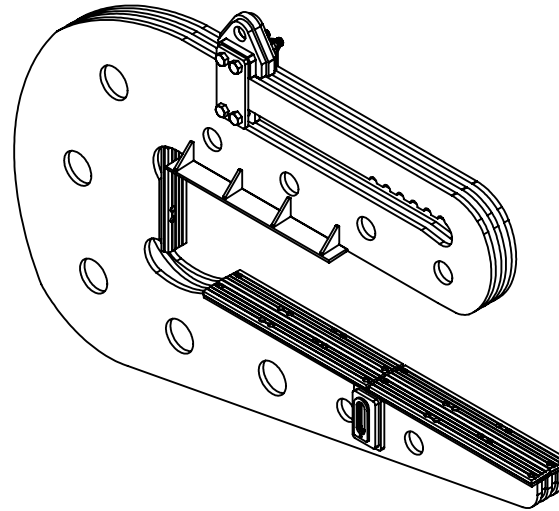

KENCO CORP.
170 STATE ROUTE 271
LIGONIER PA 15658
(800)653-6069
WWW.KENCO.COM
THE INFORMATION PROVIDED WITHIN THIS DRAWING IS THE PROPERTY OF KENCO CORP. ANY REPRODUCTION, TRANSMITTAL, OR USAGE OF ANY KIND IS PROHIBITED WITHOUT WRITTEN PERMISSION.

DIMS. = IN.
TOLERANCES:
FRACT.: ±1/16
ANG.: MACH±1°
BEND ±1°
DEC.: X.XX ±.03
X.XXX ±.01

DESCRIPTION
PH60K10

REVISION	
1	xxxxxx
DWG.	
1	