

Attachment Solutions

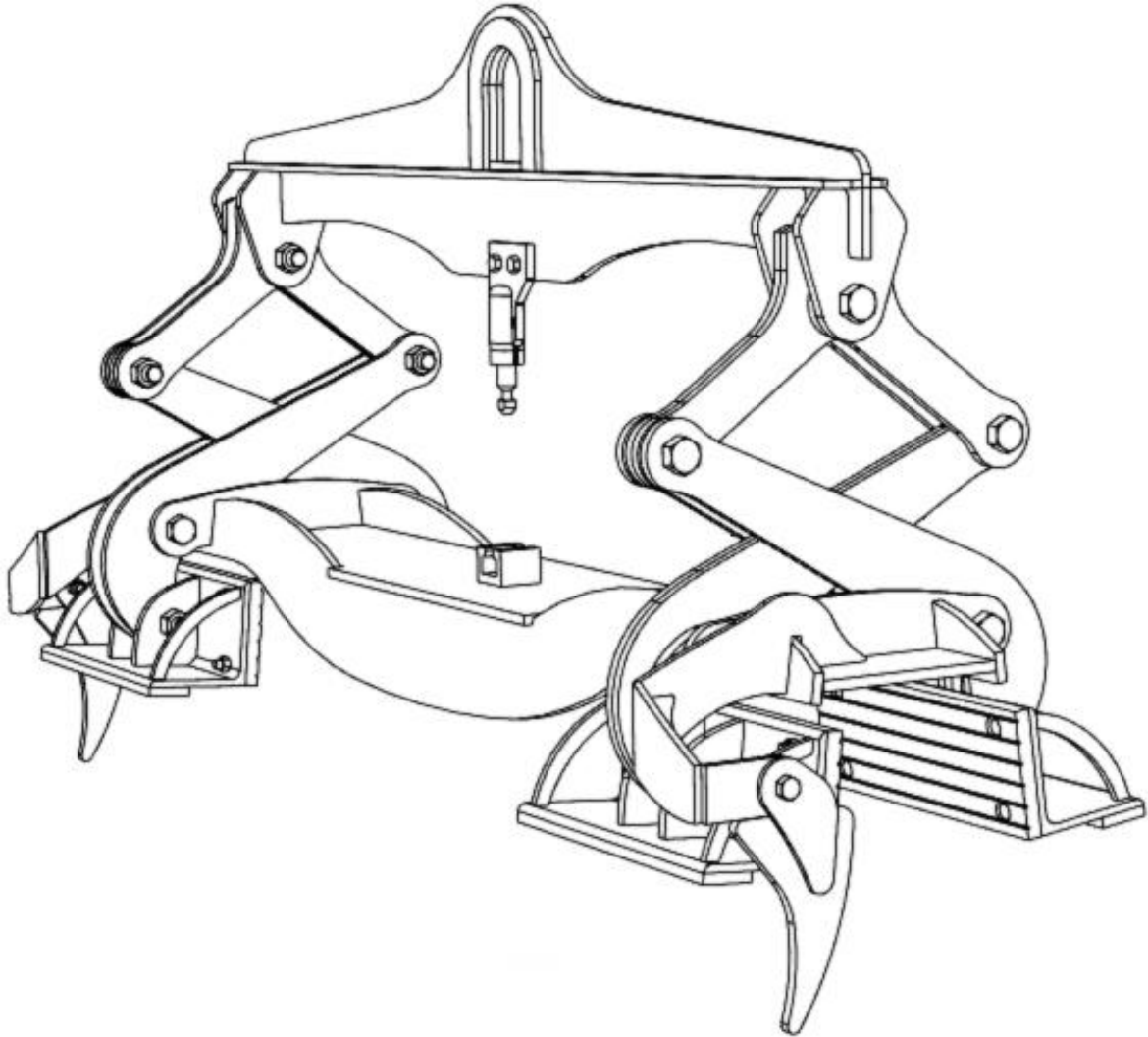

KLDL14K

Concrete median barrier handling device

Operators Manual

**Conforms to ASME B 30.20, BTH-1
Design Category B, Service Class 3**

TABLE OF CONTENTS

Section I.	General Information.	1
Section II.	Safety	1
Section III.	Identification of Major Components	3
Section IV.	Setup.....	3
Section V.	Operation.....	5
Section VI.	Maintenance.....	7
Section VII.	Inspection Criteria	8
Section VIII.	Parts/Drawings.....	9
Section IX.	Capacity.....	15
Section X.	Warranty	16

RECORD INFORMATION HERE

FOR REFERENCE

MODEL	
BODY SERIAL NUMBER	
Notes:	



Section I. General Information

May we take this opportunity to thank you for purchasing the KENCO Kenlift[®] highway median barrier wall handling system. The Kenlift[®] System provides the ultimate in below the hook concrete highway barrier handling versatility. The Kenlift[®] is quality engineered to provide years of trouble free, low maintenance performance. **Please read and fully understand this manual and any additional attached documentation before attempting to setup, operate or maintain the Kenlift[®] system.**

This manual should be made available to all persons who may use or maintain the Kenlift[®] system. For additional information, please feel free to contact the service department at Kenco at 1-800-653-6069

Section II. Safety

A. General

1. Safety practices described in this manual are intended as guidelines for safe operation under most conditions and are supplementary to any and all rules and/or laws governing any aspect of the KENCO Kenlift[®] operation that are in force in your area.
2. Before operating the KENCO Kenlift[®], you should have a clear understanding of said laws and regulations to ensure compliance.
3. Throughout this manual there are parts tagged with one or more of the following safety warnings. Particular care must be exercised with regard to these statements.



DANGER

This warning is used where there is a high probability of death or serious injury if the instructions are not followed correctly.



WARNING

This warning is used where there is a possibility of injury to yourself or others if the instructions are not followed correctly.



CAUTION

This warning is used where there is a possibility of damage to the machine if the instructions are not followed correctly.

B. Personal Safety

1. Wear appropriate protective clothing and related safety equipment including protective glasses, hardhat, gloves, protective shoes, hearing protection, and any other equipment/devices dictated by job conditions.



170 State Route 271
Ligonier, PA 15658
1-800-653-6069

2. Do not wear loose clothing, jewelry, or hairstyles that could become entangled in the KENCO Kenlift® or rigging hardware.
3. Keep hands, feet, and any other appendages clear of Kenlift® while in operation.

C. Operation Safety

1. **DO NOT ATTEMPT TO OPERATE OR PERFORM MAINTENANCE ON THE Kenlift® UNTIL READING AND FULLY UNDERSTANDING THIS MANUAL**
2. **MAINTAIN SAFE DISTANCE FROM LOAD - NEVER ALLOW KENLIFT® OR LOAD TO PASS OVER ANY PART OF A PERSON.**
3. **DO NOT USE A KENCO Kenlift® THAT HAS BEEN ALTERED ACCIDENTALLY OR INTENTIONALLY, IN ANY WAY WITHOUT INSPECTION BY QUALIFIED PERSONNEL.**
4. **DO NOT USE A KENCO Kenlift® FOR ANY TASK OTHER THAN THE INTENDED PURPOSE OF THE DESIGN.**



Section III. Identification of Major Components

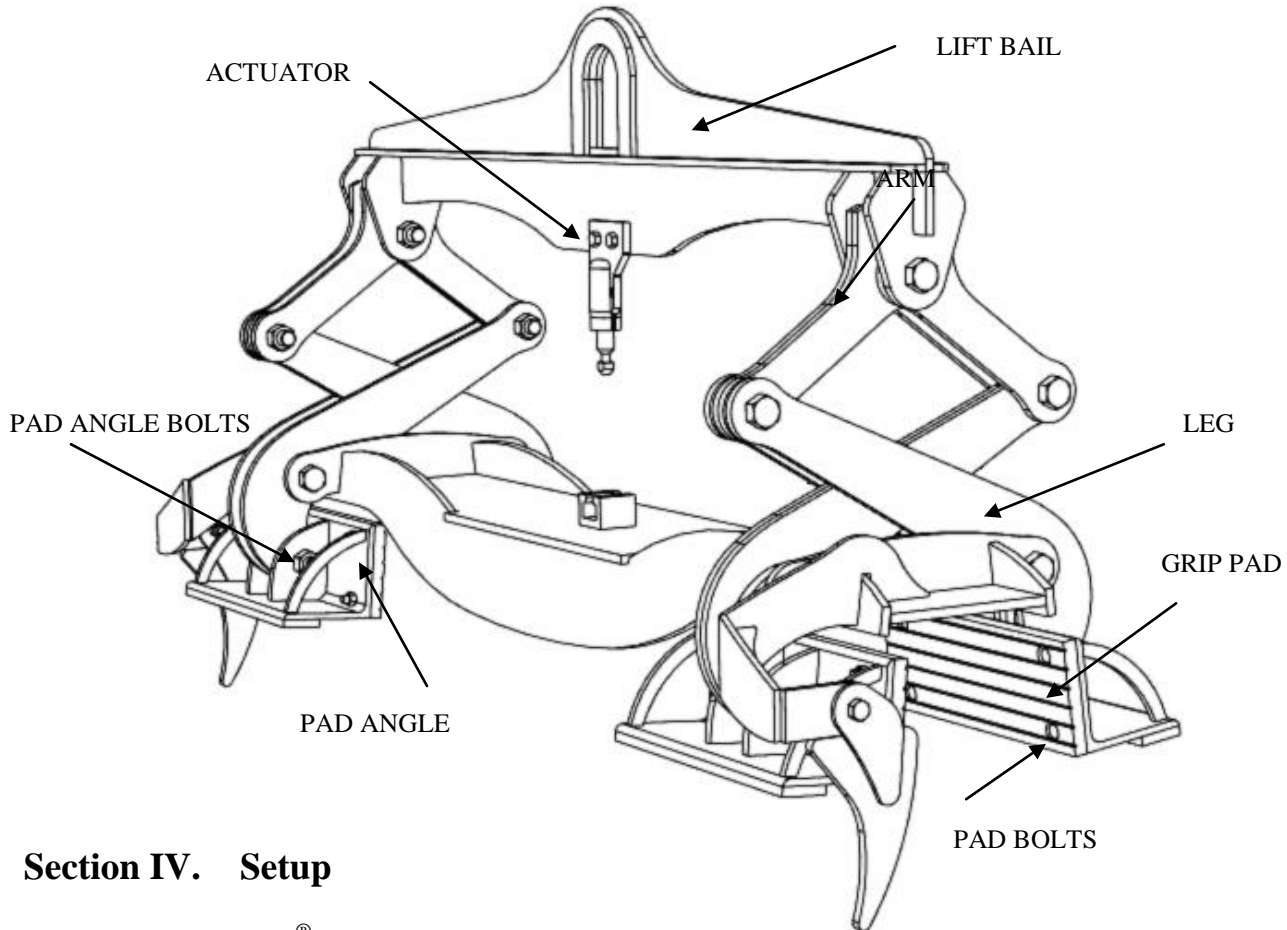

Section IV. Setup

- A. Check Kenlift[®] for any signs of damage incurred during shipping.
- B. Record model and serial #of assembly and components.
- C. Check that all pad bolts are tight.
- D. **DO NOT OVER TIGHTEN PAD ANGLE BOLTS. PAD ANGLE MUST HAVE (LIMITED) ROTATIONAL FREEDOM AT THIS POINT.**
- E. Check that all identification and warning labels are present.
- F. Attach Kenlift[®] to hoist.
 1. Use as few rigging components (shackles, slings, chain, etc.) as possible.
 2. **ALL RIGGING COMPONENTS MUST HAVE A WORKING LOAD LIMIT THAT IS EQUAL TO OR GREATER THAN THE COMBINED WEIGHT OF INTENDED LOAD PLUS THE Kenlift[®].**



170 State Route 271
Ligonier, PA 15658
1-800-653-6069

3. **UNDER NO CIRCUMSTANCES SHOULD ANY COMPONENT USED AS RIGGING TO Kenlift® BE OF A RATED CAPACITY LESS THAN THAT OF THE Kenlift®.**
4. **DO NOT RIG UNPROTECTED NYLON SLINGS OR WIRE ROPE DIRECTLY THROUGH LIFT BAIL.**
5. **IF USING EQUIPMENT OTHER THAN A CRANE: USE RIGGING OF SUFFICIENT LENGTH TO PREVENT CONTACT BETWEEN Kenlift® AND EQUIPMENT.**



Section V. Operation



DANGER

*Before attempting to use the Kenlift[®] device **ALWAYS** perform a test lift on the intended object(s) to confirm proper operation. **DO NOT** use a Kenlift[®] to handle objects beyond the rated capacity or range.*



DANGER

*Manipulation of the Kenlift[®] by ground personnel for the purpose of alignment with load shall only be done with Kenlift suspended above the wall. **KEEP ALL HANDS AWAY FROM Kenlift DURING OPERATION.***



DANGER

*Pads and surfaces of the load that come into contact with the pad surfaces **MUST BE CLEAN** and free of any foreign material or coating that could compromise the grip.*

A. Operation

1. Ensure that the Kenlift[®]'s capacity and range are appropriate to the median barrier wall(s) to be handled.
2. Ensure pads are clean and free of debris or contamination.
3. Position Kenlift[®] at or near center of object(s) to be lifted.
4. Lower Kenlift[®] onto object(s), taking care to minimize impact.
5. Ensure that all persons are clear of Kenlift[®] and wall.
6. Release tension on lift cable.
7. Raise Kenlift[®] and load in a smooth motion, do not "jerk".
8. Deposit at desired location.
9. Release tension on lift cable. (Note: avoid undue slamming of the Kenlift[®] into open position to prolong actuator life.)
10. Remove Kenlift[®] (Kenlift[®] is latched in open position automatically)

Tip: The majority of wear on the Kenlift[®], pads, and associated components results from shock loading, impacting, and poor alignment of the Kenlift[®] with the load. Minimizing these incidents will greatly extend the life of the Kenlift[®] and consumables.

B. AVOID JARRING, WEINGING, AND OTHERWISE UNNECESSARY MANIPULATION OF THE LOAD.

C. AVOID HANDLING OF LOADS OFF CENTER.

D. OBSERVE ALL SAFETY PRACTICES ASSOCIATED WITH OPERATION OF HOIST MACHINERY.

E. DO NOT USE Kenlift[®] TO DRAG LOADS.

F. DO NOT ALLOW LOAD (BARRIER SECTION) TO CONTACT ANY SURFACE/OBJECT WHILE BEING HANDLED.



*The Kenlift[®] barrier handling device produces grip **proportional to and dependent on** the weight of the barrier wall. It is for this reason that while in operation the Kenlift and wall **NEVER** be allowed to contact other items.*

Section VI. Maintenance

A. Daily:

1. Visually inspect Kenlift® for signs of stress and wear.
2. Check that bolts and nuts are snug.
3. Ensure free movement of all components.
4. Ensure that all warning labels are present and readable.
5. Check that actuator mounting screws are snug and seated.
6. Lubricate all moving mechanisms with penetrating oil.
7. **LUBRICATE ACTUATOR WITH LIGHT PENETRATING OIL ONLY (WD40™)**
8. For Pads:
 - a. Check that all pad mounting bolts and nuts are tight.
 - b. Verify freedom of rotation for pad angle.
 - c. Ensure that pad material is sound, and not de-laminated from backing plates.
 - d. Ensure that pad mounting bolt heads are min. 3/32" below the surface of the pad.
 - e. Ensure pads are clean and free of any foreign material or substance.

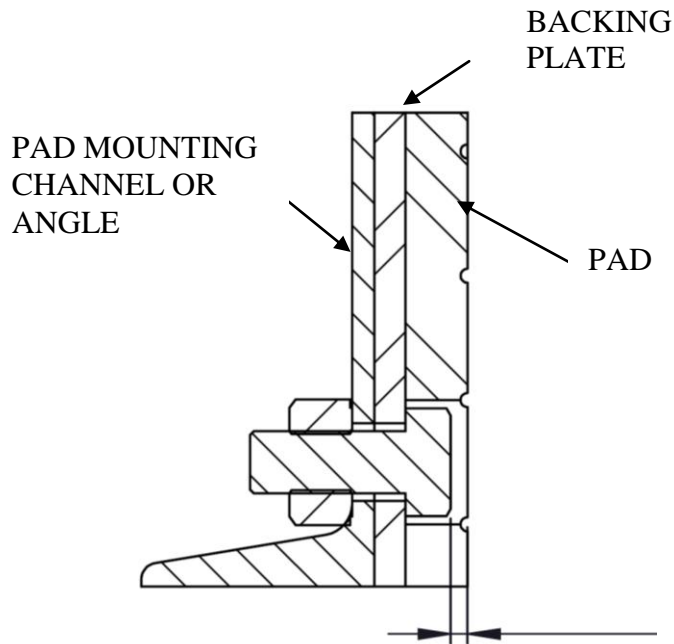

B. Annually*

1. Remove pivot bolts and washers, coat with grease.
2. Inspect holes, pins, bolts etc. for wear. See sect VII for criteria.
3. Remove actuator, clean and lubricate with light penetrating oil – check for signs of wear, replace if necessary.

* Frequency depends on usage, environmental conditions, etc.

Section VII. Inspection Criteria

THE KENLIFT® UNIT AND ALL OF ITS ASSOCIATED COMPONENTS SHALL BE REMOVED FROM SERVICE AND TAGGED APPROPRIATELY UNTIL RECERTIFICATION BY A QUALIFIED INDIVIDUAL IN ANY OF THE FOLLOWING CONDITIONS:

A. General

1. Cracking in any component or member.
2. Cracking in any weld.
3. Visible distortion in any member.
4. Visible distortion in any Bolt/Pin/Shaft.

B. Specific

1. Lift Bail

- a. The lift bail shall be replaced if a 20% loss in cross-sectional area from the original member(s) can be demonstrated. Note: cross section of welds, “mushroomed” wear faces, and burrs are not accounted for as cross-sectional area. (See ill.)

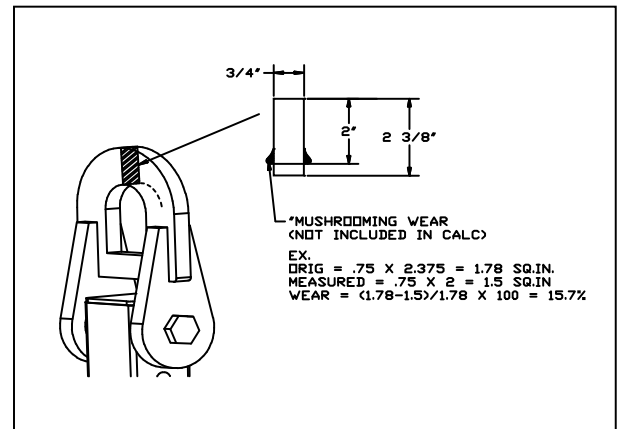

2. Holes

- a. Any members through which bolted or pinned connections pass shall be replaced if a 10% loss in cross-sectional area from the original member(s) can be demonstrated. Note: cross section of welds, “mushroomed” wear faces, and burrs are not accounted for as cross-sectional area.

3. Pins/Bolts

- a. Any visible deformation of a pin, shaft or bolt shall require replacement of that part.

4. Pads – Replace if:

- a. For units utilizing urethane gripping pads, if surface of any given mounting bolt is not at least 3/32” below the surface of the pad,.
- b. Any de-lamination of the pad from the backing plate.
- c. Any scarring, chunking, or missing pad material constituting a total combined loss of surface area greater than 3 sq. in. per pad.
- d. Any single scar, chunk, or missing pad face that is greater than 1 sq. in per pad.

Section VIII. Parts/Drawings

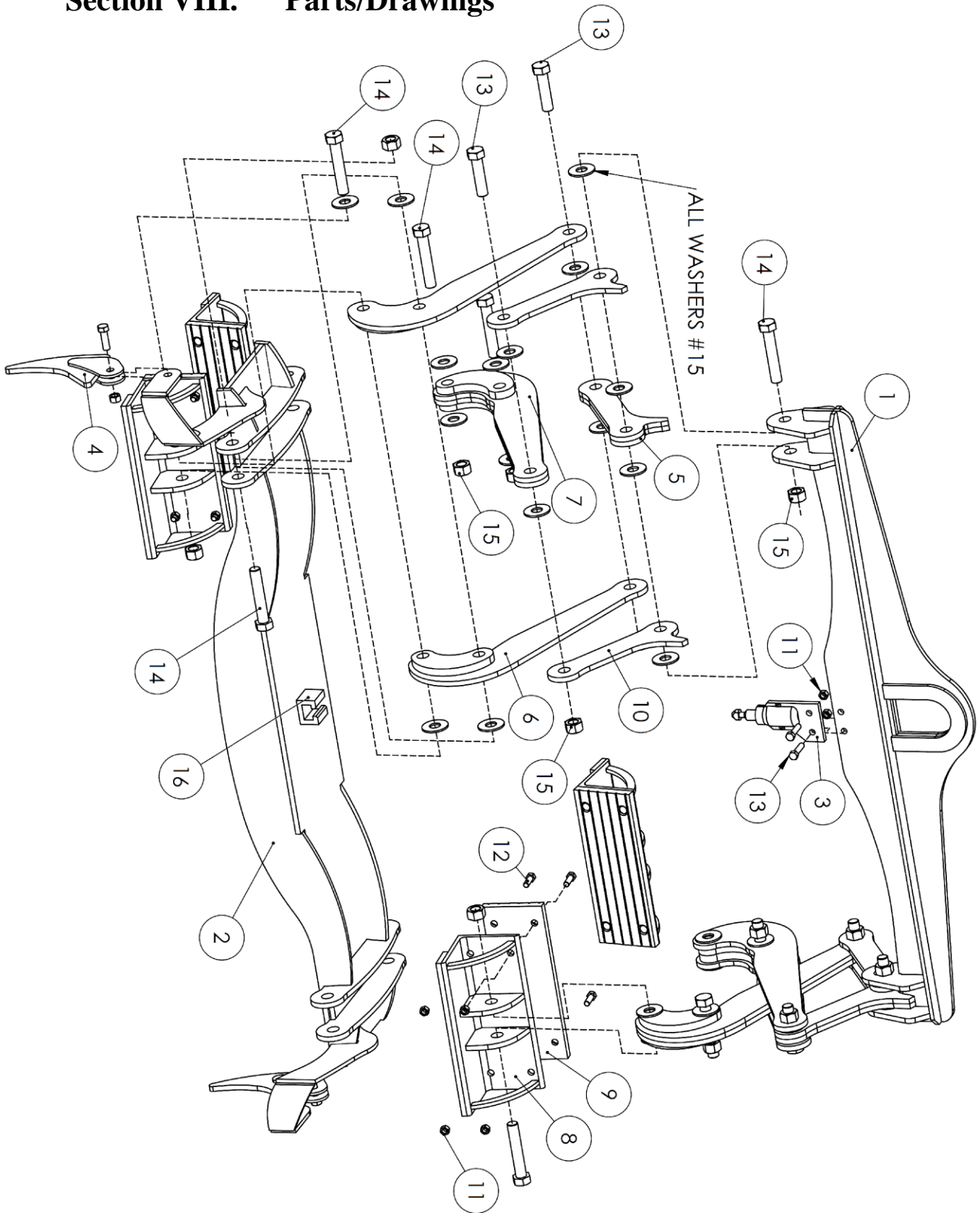

17

DANGER
DO NOT STAND UNDER OR NEAR
WHILE MACHINE IS OPERATING

18

KENCO CORPORATION
877-4ATTACH

MODEL

USAGE

CAPACITY WT

SERIAL NO.

21

 **WARNING**



Read and understand operator's manual before using this equipment.

Failure to follow operating and maintenance procedures could result in death or serious injury.

19

THIS LIFTER IS DESIGNED TO ASME BTH-1
DESIGN CATEGORY SERVICE CLASS

20

 **WARNING**

- DO NOT** exceed the rated load capacity of the lifter.
- DO NOT** attempt to operate a malfunctioning or damaged unit.
- DO NOT** allow unit or load to pass over any part of a person.
- DO NOT** leave a suspended load unattended.
- DO NOT** remove or obscure any labels or markings.
- DO NOT** operate or service without first having read and understood the operating manual.
- DO NOT** lift loads higher than necessary.
- DO NOT** alter or modify this equipment.
- DO NOT** use lifter for other than designated purposes.
- DO NOT** lift unbalanced loads.
- DO NOT** allow load to contact other objects while suspended.

INSPECT LIFTER PRIOR TO EACH USE.

22 (ex.)



Model: KL 12000
Unit Weight: 900 lbs.
Capacity: 12000 lbs.
Usage: 16' - 20' Barrier Wall

170 State Route 271, Ligonier, PA 15658
www.kenco.com 1-877-4-ATTACH



NO	QTY	NAME
1	1	LIFT BALE ASSEMBLY
2	1	CHANNEL ASSEMBLY
3	1	MEDIUM ACTUATOR
4	2	ALIGN DOG
5	2	SINGLE ARM ASSEMBLY
6	4	DOUBLE LEG ASSEMBLY
7	2	SINGLE LEG ASSEMBLY
8	4	PAD ANGLE ASSEMBLY
9	2	16X6 PAD
10	4	ARM
11	18	0.5" NUT
12	16	0.5" X 3.25" GR.8 BOLT
13	2	0.5" X 2" GR.8 BOLT
14	10	1.0" X 5.5" GR.8 BOLT
15	14	1.0" NYLOCK NUT
16	1	ACTUATOR RECEIVER
17	4	DANGER STICKER
18	1	IDTAG
19	1	BTH TAG
20	1	LG. WARNING STICKER
21	1	SM. WARNING STICKER
22	1	ID STICKER

Section IX. Capacity

A. General

Due to the manner in which the Double Lift engages two walls at once, special consideration must be taken for each lift. When lifting two walls at once, extra forces are applied to the Double Lift not normally seen when lifting just one wall.

B. Single Wall Pick

A single wall with a minimum 6' (1.8m) length and a maximum weight of 14,000lbs (6350kg) can be lifted.

C. Double Wall Pick

Two walls being lifted at once must be mechanically linked or have ends touching. Refer to the table below to ensure the walls being lifted are within the Double Lift's design parameters.

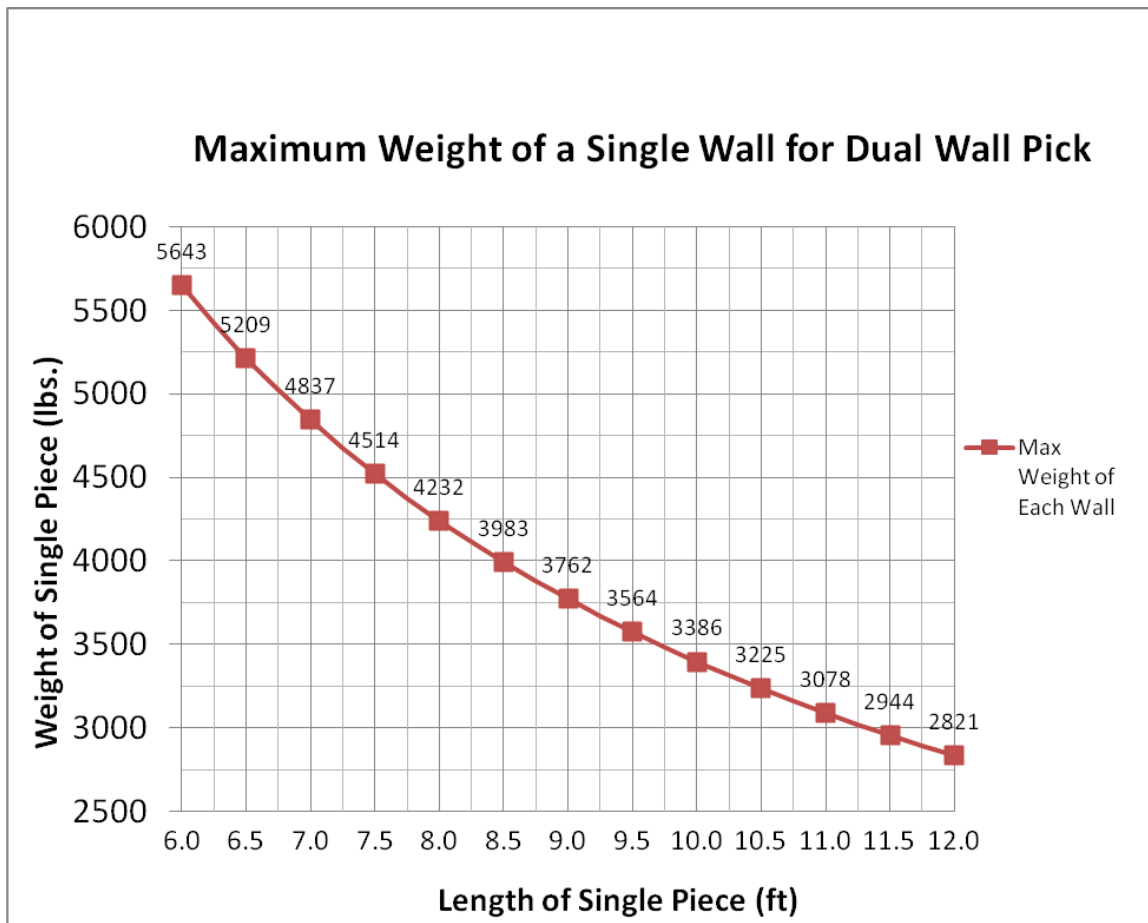

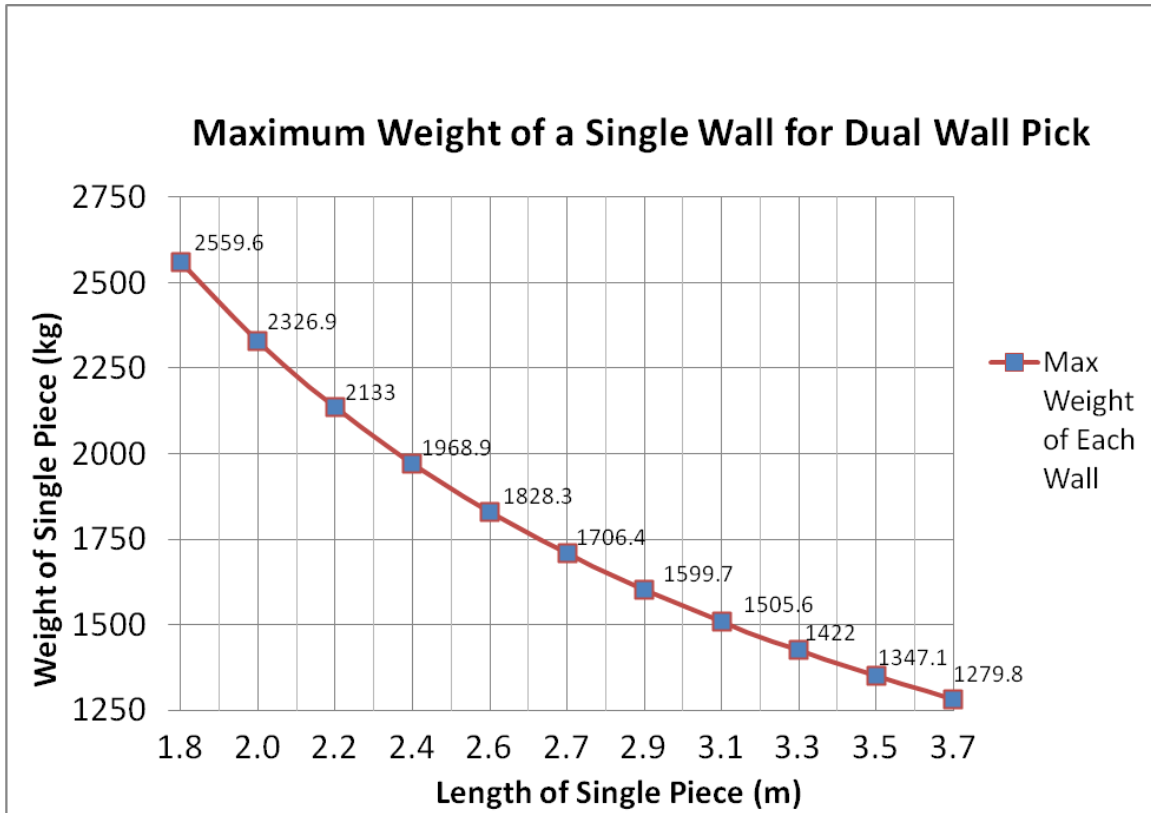



Section X. Warranty

A. Policy

1. KENCO Corporation (KENCO) warrants the KENCO Kenlift[®] lifting device (not including pads or consumable items) sold by KENCO to be free from proven defects in material and workmanship for a period of six (6) months from the delivery date to the original customer.
2. Warranty is limited to replacement of parts and/or assemblies, which upon inspection by KENCO are deemed to be defective in material, workmanship, or both.
3. Warranty shall not extend to products that have been altered or repaired in any way without the express written consent of KENCO.
4. Warranty shall not extend to any product that has been misused, abused, or improperly applied or any defect resulting thereof.
5. Defects and corrosion that are the result of improper storage and/or maintenance are not warrantable.
6. Wear items such as Pads, Pins or Lifting bails etc. are not considered for warranty claims.

B. Disclaimer

1. THIS WARRANTY IS EXCLUSIVE AND IN LIEU OF ALL OTHER REPRESENTATIONS AND WARRANTIES EXPRESSED OR IMPLIED, AND KENCO EXPLICITLY DISCLAIMS AND EXCLUDES ANY IMPLIED WARRANTY OF MERCHANTABILITY FOR A PARTICULAR PURPOSE. IN NO EVENT SHALL THE END USER BE ENTITLED TO ANY CONSEQUENTIAL, INCIDENTAL OR CONTINGENT DAMAGES OF ANY KIND ARISING OUT OF BREACH OF CONTRACT, WARRANTY (INCLUDING NEGLIGENCE AND STRICT LIABILITY) OR OTHER THEORIES OF LAW, WITH RESPECT TO PRODUCTS SOLD OR SERVICES RENDERED BY KENCO, OR ANY UNDERTAKINGS, ACTS OR OMISSIONS RELATING THERETO.