

Attachment Solutions

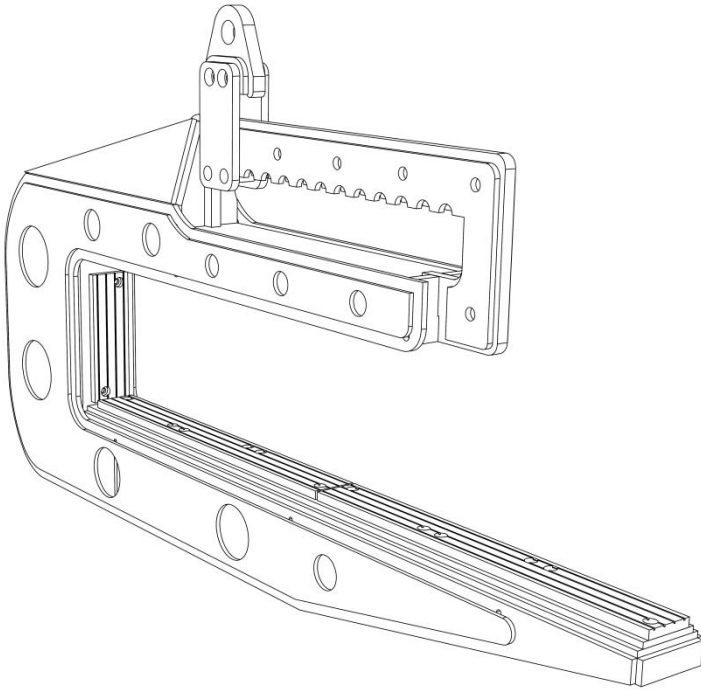

The Kenco Pipe Hook

Concrete pipe handling device

Operators Manual

Conforms to ASME B 30.20, BTH-1

Design Category B, Service Class 3

TABLE OF CONTENTS

Section I.	General Information.....	1
Section II.	Safety.....	1
Section III.	Identification of Major Components.....	3
Section IV.	Setup.....	4
Section V.	Operation.....	5
Section VI.	Maintenance.....	8
Section VII.	Inspection Criteria.....	9
Section VIII.	Parts/Drawings.....	11
Section IX.	Available Options.....	17
Section X.	Warranty.....	17

RECORD INFORMATION HERE FOR REFERENCE

MODEL	
BODY SERIAL NUMBER	
Notes:	



Section I. General Information

May we take this opportunity to thank you for purchasing the KENCO Pipe Hook concrete pipe handling system. The Pipe Hook System provides the ultimate in below the hook concrete pipe versatility. The Pipe Hook is quality engineered to provide years of trouble free, low maintenance performance. **Please read and fully understand this manual and any additional attached documentation before attempting to setup, operate or maintain the Pipe Hook system.**

This manual should be made available to all persons who may use or maintain the Pipe Hook system. For additional information, please feel free to contact the service department at Kenco at 1-800-653-6069

Section II. Safety

A. General

1. Safety practices described in this manual are intended as guidelines for safe operation under most conditions and are supplementary to any and all rules and/or laws governing any aspect of the KENCO Pipe Hook operation that are in force in your area.
2. Before operating the KENCO Pipe Hook, you should have a clear understanding of said laws and regulations to ensure compliance.
3. Throughout this manual there are parts tagged with one or more of the following safety warnings. Particular care must be exercised with regard to these statements.

***DANGER***

This warning is used where there is a high probability of death or serious injury if the instructions are not followed correctly.

***WARNING***

This warning is used where there is a possibility of injury to yourself or others if the instructions are not followed correctly.

***CAUTION***

This warning is used where there is a possibility of damage to the machine if the instructions are not followed correctly.

B. Personal Safety

1. Wear appropriate protective clothing and related safety equipment including protective glasses, hardhat, gloves, protective shoes, hearing protection, and any other equipment/devices dictated by job conditions.
2. Do not wear loose clothing, jewelry, or hairstyles that could become entangled in the KENCO Pipe Hook or rigging hardware.
3. Keep hands, feet, and any other appendages clear of the Pipe Hook while in operation



C. Operation Safety

1. **DO NOT ATTEMPT TO OPERATE OR PERFORM MAINTENANCE ON THE PIPE HOOK UNTIL READING AND FULLY UNDERSTANDING THIS MANUAL**
2. **MAINTAIN SAFE DISTANCE FROM LOAD - NEVER ALLOW PIPE HOOK OR LOAD TO PASS OVER ANY PART OF A PERSON.**
3. **DO NOT USE A KENCO PIPE HOOK THAT HAS BEEN ALTERED ACCIDENTALLY OR INTENTIONALLY, IN ANY WAY WITHOUT INSPECTION BY QUALIFIED PERSONNEL.**
4. **DO NOT USE A KENCO PIPE HOOK FOR ANY TASK OTHER THAN THE INTENDED PURPOSE OF THE DESIGN.**

Section III. Identification of Major Components

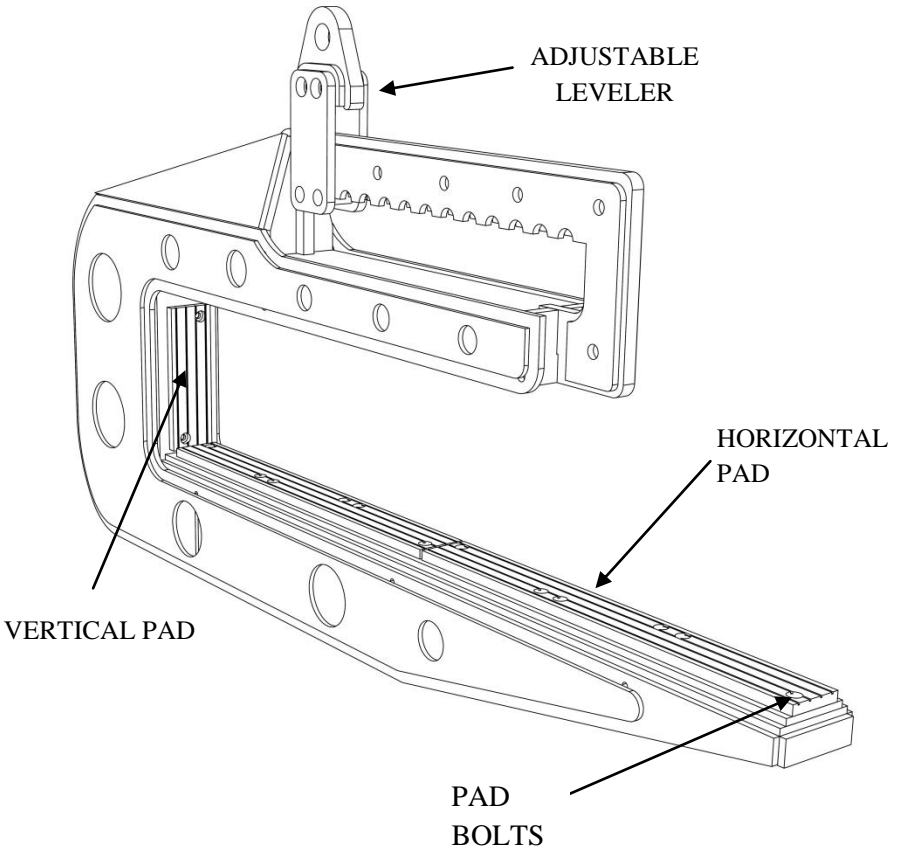





Section IV. Setup

- A. Check The Pipe Hook for any signs of damage incurred during shipping.
- B. Record model and serial #of assembly and components.
- C. Check that all pad bolts are tight.
- D. Check that all identification and warning labels are present.
- E. Attach Pipe Hook to hoist.
 1. Use as few rigging components (shackles, slings, chain, etc.) as possible.
 2. **ALL RIGGING COMPONENTS MUST HAVE A WORKING LOAD LIMIT THAT IS EQUAL TO OR GREATER THAN THE COMBINED WEIGHT OF INTENDED LOAD PLUS THE PIPE HOOK.**
 3. **UNDER NO CIRCUMSTANCES SHOULD ANY COMPONENT USED AS RIGGING TO THE PIPE HOOK BE OF A RATED CAPACITY LESS THAN THAT OF THE PIPE HOOK.**
 4. **DO NOT RIG UNPROTECTED NYLON SLINGS OR WIRE ROPE DIRECTLY THROUGH LIFT BAIL.**
 5. **IF USING EQUIPMENT OTHER THAN A CRANE: USE RIGGING OF SUFFICIENT LENGTH TO PREVENT CONTACT BETWEEN PIPE HOOK AND EQUIPMENT.**

Section V. Operation

 **DANGER** *Before attempting to use the pipe hook device **ALWAYS** perform a test lift on the intended object(s) to confirm proper operation. **DO NOT** use a pipe hook to handle objects beyond the rated capacity or*

 **DANGER** *Manipulation of the Pipe Hook by ground personnel for the purpose of alignment with load shall only be done with Pipe Hook suspended above the wall. **KEEP ALL HANDS AWAY FROM Pipe Hook***

 **DANGER** *Surfaces of the load that come into contact with the gripping surfaces must be free of any foreign material or coating that could compromise the grip.*

A. Operation

1. Ensure that the Pipe Hook's capacity and range are appropriate to the pipe to be handled.
2. Ensure pads are clean and free of debris or contamination.
3. Position Pipe Hook inside pipe by ensuring **VERTICAL PAD** is contacting end of pipe while taking care not to damage pipe.
4. Ensure that all persons are clear of Pipe Hook and pipe.
5. Lower Pipe Hook onto center of pipe and slide the **ADJUSTABLE LEVELER** to the appropriate slot for the pipe being lifted.
6. Raise Pipe Hook and load in a smooth motion, do not "jerk".
7. Deposit at desired location
8. Lower Pipe Hook onto center of pipe and slide the **ADJUSTABLE LEVELER** to its furthest back position and remove Pipe Hook.

Tip: The majority of wear on the Pipe Hook will result from shock loading, impacting, and poor alignment of the Pipe Hook with the load. Minimizing these incidents will greatly extend the life of the Pipe Hook and consumables.

- B. **AVOID JARRING, WEINGING, AND OTHERWISE UNNECESSARY MANIPULATION OF THE LOAD.**
- C. **AVOID HANDLING OF LOADS OFF CENTER.**
- D. **DO NOT USE THE PIPE HOOK TO PICK MULTIPLES OF ITEMS IN A SINGLE PICK.**
- E. **OBSERVE ALL SAFETY PRACTICES ASSOCIATED WITH OPERATION OF HOIST MACHINERY.**
- F. **DO NOT USE PIPE HOOK TO DRAG LOADS.**
- G. **DO NOT ALLOW LOAD TO CONTACT ANY SURFACE/OBJECT WHILE BEING HANDLED.**

Section VI. Maintenance

A. Daily:

1. Visually inspect Pipe Hook for signs of stress and wear.
2. Check that bolts and nuts are snug.
3. Ensure free movement of all components.
4. Ensure that all warning labels are present and readable.
5. Lubricate all moving mechanisms with penetrating **OIL**.
6. **LUBRICATE ACTUATOR WITH LIGHT PENETRATING OIL ONLY (WD40™)**
7. For Pads:
 - a. Check that all pad mounting bolts and nuts are tight.
 - b. Ensure that pad material is sound, and not de-laminated from backing plates.
 - c. Ensure that pad mounting bolts heads are min. $3/32''$ below the surface of the pad. (see ill.)
 - d. Ensure pads are clean and free of any foreign material or substance.

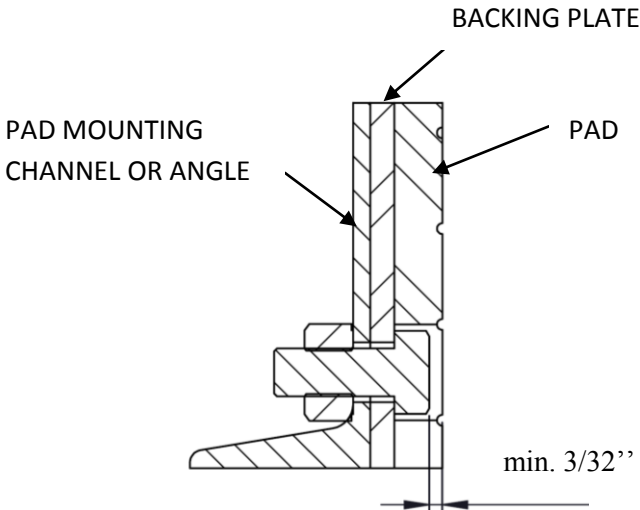



B. Annually*

1. Remove pivot bolts and washers, coat with grease.
2. Inspect holes, pins, bolts etc. for wear. See sect VII for criteria.

* *Frequency depends on usage, environmental conditions, etc.*

Section VII. Inspection Criteria

THE PIPE HOOK UNIT AND ALL OF ITS ASSOCIATED COMPONENTS SHALL BE REMOVED FROM SERVICE AND TAGGED APPROPRIATELY UNTIL RECERTIFICATION BY A QUALIFIED INDIVIDUAL IN ANY OF THE FOLLOWING CONDITIONS:

A. General

1. **Cracking in any component or member.**
2. **Cracking in any weld.**
3. **Visible distortion in any member.**
4. **Visible distortion in any Bolt/Pin/Shaft.**

B. Specific

1. Lift Bail

- a. The lift bail shall be replaced if a 20% loss in cross-sectional area from the original member(s) can be demonstrated. Note: cross section of welds, “mushroomed” wear faces, and burrs are not accounted for as cross-sectional area. (see ill.)

2. Holes

- a. Any members through which bolted or pinned connections pass shall be replaced if a 10% loss in cross-sectional area from the original member(s) can be demonstrated. Note: cross section of welds, “mushroomed” wear faces, and burrs are not accounted for as cross-sectional area.

3. Pins/Bolts

- a. Any visible deformation of a pin, shaft or bolt shall require replacement of that part.

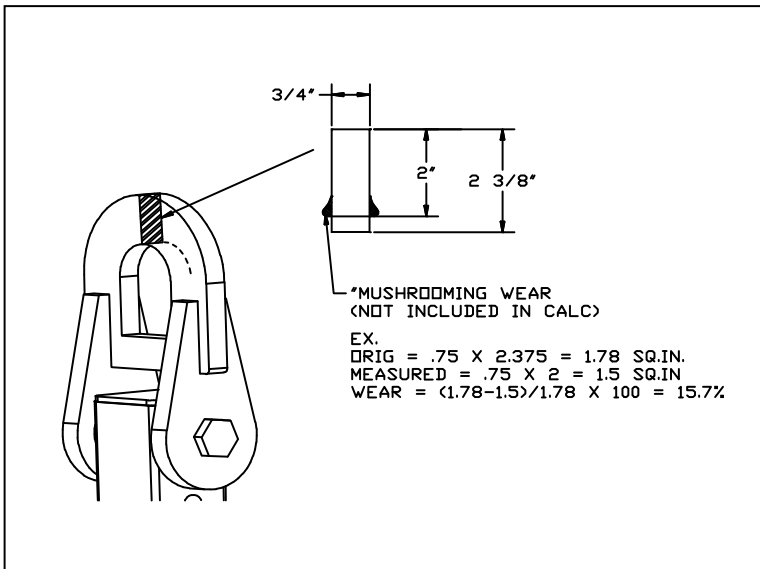

Section VIII. Parts/Drawings

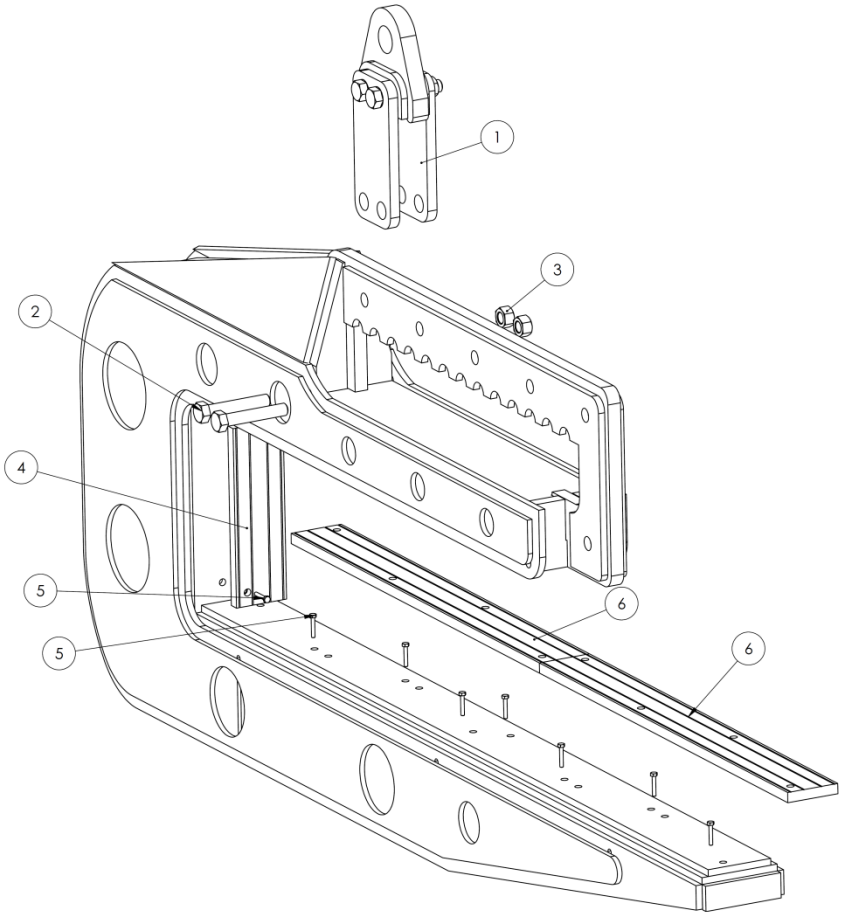

22

DANGER

**DO NOT STAND UNDER OR NEAR
WHILE MACHINE IS OPERATING**

23

KENCO CORPORATION

877-4ATTACH

MODEL





WT.

USAGE

24

THIS LIFTER IS DESIGNED TO ASME BTH-1

 WARNING	
	<p><u>DO NOT</u> exceed the rated load capacity of the lifter.</p> <p><u>DO NOT</u> attempt to operate a malfunctioning or damaged unit.</p>
25	<p><u>DO NOT</u> allow unit or load to pass over any part of a person.</p> <p><u>DO NOT</u> leave a suspended load unattended.</p> <p><u>DO NOT</u> remove or obscure any labels or markings.</p> <p><u>DO NOT</u> operate or service without first having read and understood the operating manual.</p>

 WARNING			
26	<table border="1"><tr><td></td><td><p>Read and understand operator's manual before using this equipment.</p><p>Failure to follow operating and maintenance procedures</p></td></tr></table>		<p>Read and understand operator's manual before using this equipment.</p> <p>Failure to follow operating and maintenance procedures</p>
	<p>Read and understand operator's manual before using this equipment.</p> <p>Failure to follow operating and maintenance procedures</p>		

27 (ex.)



Model: KL 12000
Unit Weight: 900 lbs.
Capacity: 12000 lbs.
Usage: 16' - 20' Barrier Wall

170 State Route 271, Ligonier, PA 15658
 www.kenco.com 1-877-4-ATTACH

NO	QTY	NAME
1	1	LIFT BALE ASSEMBLY
2	2	LIFT BALE BOLT
3	2	LIFT BAIL NUT
4	1	4X13 PAD
5	9	PAD BOLT
6	2	4X36 PAD
22-27	#	ID& SAFETY TAGS



Section X. Warranty

A. Policy

1. KENCO Corporation (KENCO) warrants the KENCO Pipe Hook lifting device (not including consumable items) sold by KENCO to be free from proven defects in material and workmanship for a period of six (6) months from the delivery date to the original customer.
2. Warranty is limited to replacement of parts and/or assemblies, which upon inspection by KENCO are deemed to be defective in material, workmanship, or both.
3. Warranty shall not extend to products that have been altered or repaired in any way without the express written consent of KENCO.
4. Warranty shall not extend to any product that has been misused, abused, or improperly applied or any defect resulting thereof.
5. Defects and corrosion that are the result of improper storage and/or maintenance are not warrantable.
6. Wear items such as Pins or Lifting bails etc. are not considered for warranty claims.



B. Disclaimer

1. THIS WARRANTY IS EXCLUSIVE AND IN LIEU OF ALL OTHER REPRESENTATIONS AND WARRANTIES EXPRESSED OR IMPLIED, AND KENCO EXPLICITLY DISCLAIMS AND EXCLUDES ANY IMPLIED WARRANTY OF MERCHANTABILITY FOR A PARTICULAR PURPOSE. IN NO EVENT SHALL THE END USER BE ENTITLED TO ANY CONSEQUENTIAL, INCIDENTAL OR CONTINGENT DAMAGES OF ANY KIND ARISING OUT OF BREACH OF CONTRACT, WARRANTY (INCLUDING NEGLIGENCE AND STRICT LIABILITY) OR OTHER THEORIES OF LAW, WITH RESPECT TO PRODUCTS SOLD OR SERVICES RENDERED BY KENCO, OR ANY UNDERTAKINGS, ACTS OR OMISSIONS RELATING THERETO.