

**Attachment Solutions**

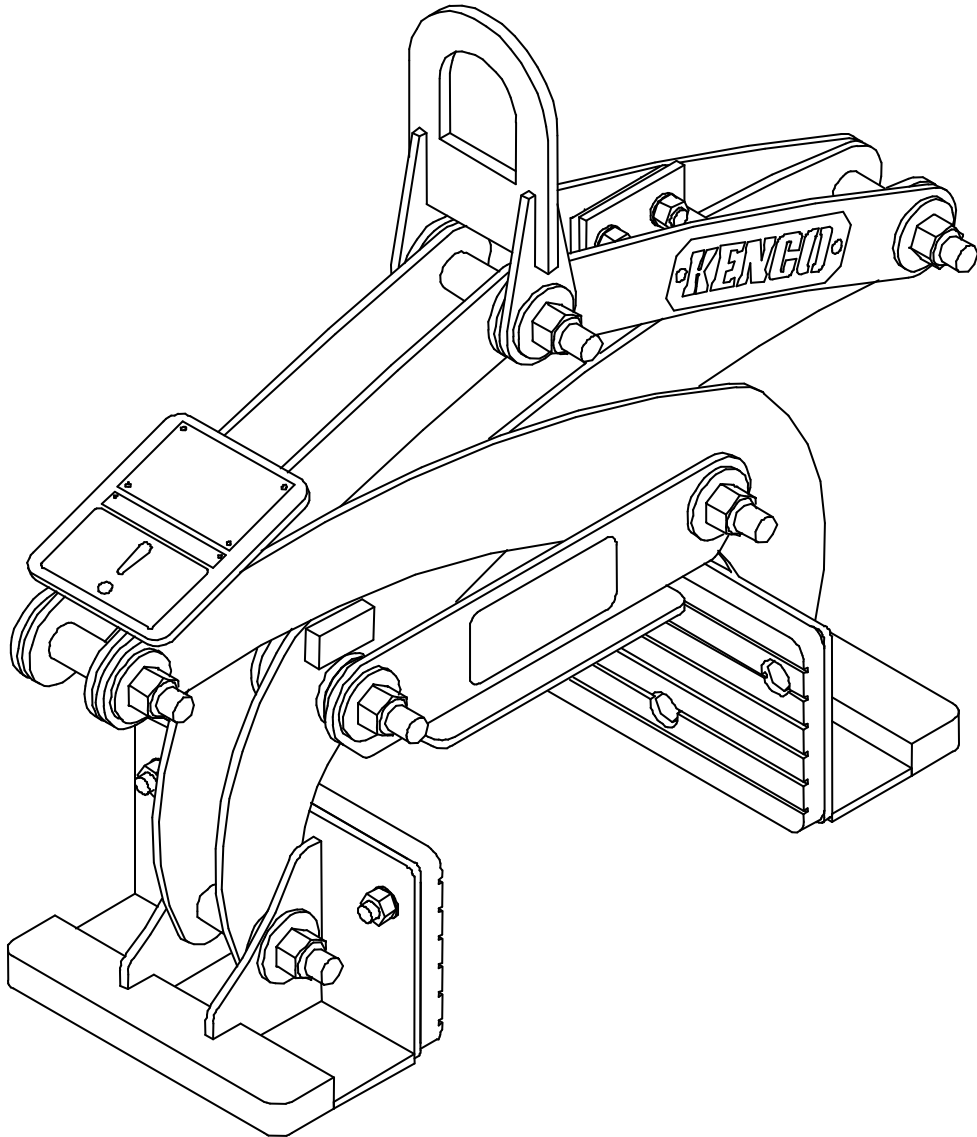

# **TOMBSTONE LIFTER**

## **TSL15C3T12**

**Operators Manual**

**Conforms to ASME B 30.20-2010 and**

**BTH-1-2008**



170 State Route 271  
 Ligonier, PA 15658  
 1-800-653-6069

**TABLE OF CONTENTS**

**Section I. General Information.....3**

**Section II. Safety.....3**

**Section III. Identification of Major Components .....5**

**Section IV. Setup.....5**

**Section V. Operation.....7**

**Section VI. Maintenance .....9**

**Section VII. Inspection Criteria.....10**

**Section VIII. Parts/Drawings .....11**

**Section IX. Warranty .....15**

**RECORD INFORMATION HERE**

**FOR REFERENCE**

<b>MODEL</b>	
<b>BODY SERIAL NUMBER</b>	
<b>Notes:</b>	



170 State Route 271  
Ligonier, PA 15658  
1-800-653-6069

## Section I. General Information.

May we take this opportunity to thank you for purchasing the Kenco Custom Tombstone Lifter. The Custom Tombstone Lifter provides the ultimate in below the hook Block handling versatility. The Custom Tombstone Lifter is quality engineered to provide years of trouble free, low maintenance performance. **Please read and fully understand this manual and any additional attached documentation before attempting to setup, operate or maintain the Custom Tombstone Lifter system.**

This manual should be made available to all persons who may use or maintain the Custom Tombstone Lifter system. For additional information, please feel free to contact the service department at Kenco at 1-800-653-6069

## Section II. Safety

### A. General

1. Safety practices described in this manual are intended as guidelines for safe operation under most conditions and are supplementary to any and all rules and/or laws governing any aspect of the Kenco Custom Tombstone Lifter operation that are in force in your area.
2. Before operating the Kenco Custom Tombstone Lifter, you should have a clear understanding of said laws and regulations to ensure compliance.
3. Throughout this manual there are parts tagged with one or more of the following safety warnings. Particular care must be exercised with regard to these statements.



This warning is used where there is a high probability of death or serious injury if the instructions are not followed correctly.



This warning is used where there is a possibility of injury to yourself or others if the instructions are not followed correctly.



This warning is used where there is a possibility of damage to the machine if the instructions are not followed correctly.



## B. Personal Safety

1. Wear appropriate protective clothing and related safety equipment including protective glasses, hardhat, gloves, protective shoes, hearing protection, and any other equipment/devices dictated by job conditions.
2. Do not wear loose clothing, jewelry, or hairstyles that could become entangled in the Kenco Custom Tombstone Lifter or rigging hardware.
3. Keep hands, feet, and any other appendages clear of the Custom Tombstone Lifter while in operation.

## C. Operation Safety.

1. **DO NOT ATTEMPT TO OPERATE OR PERFORM MAINTENANCE ON THE CUSTOM TOMBSTONE LIFTER UNTIL READING AND FULLY UNDERSTANDING THIS MANUAL**
2. **MAINTAIN SAFE DISTANCE FROM LOAD - NEVER ALLOW THE CUSTOM TOMBSTONE LIFTER OR LOAD TO PASS OVER ANY PART OF A PERSON.**
3. **DO NOT USE A KENCO CUSTOM TOMBSTONE LIFTER THAT HAS BEEN ALTERED ACCIDENTALLY OR INTENTIONALLY, IN ANY WAY WITHOUT INSPECTION BY QUALIFIED PERSONNEL.**
4. **DO NOT USE A KENCO CUSTOM TOMBSTONE LIFTER FOR ANY TASK OTHER THAN THE INTENDED PURPOSE OF THE DESIGN.**

### Section III. Identification of Major Components

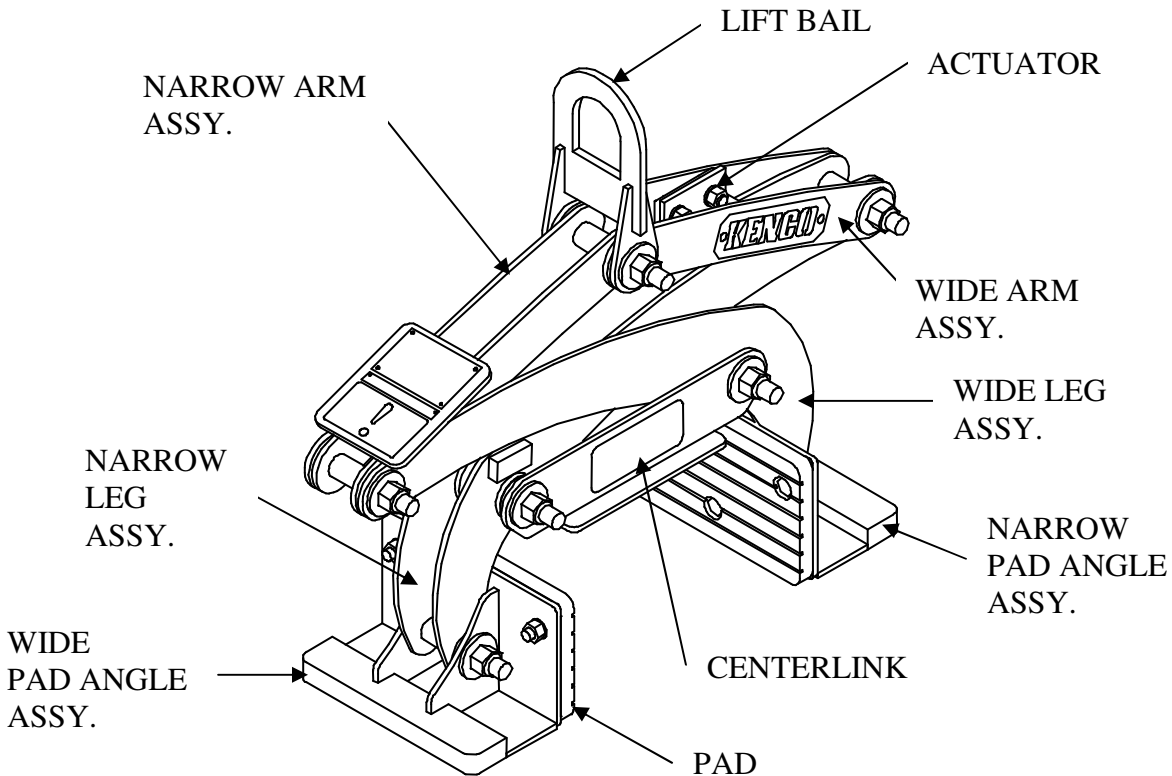

### Section IV. Setup.

- A. Check the Custom Tombstone Lifter for any signs of damage incurred during shipping.
- B. Record model and serial # of assembly and components.
- C. Attach the Custom Tombstone Lifter to hoist.
  1. Use as few rigging components (shackles, slings, chain, etc.) as possible.
  2. **ALL RIGGING COMPONENTS MUST HAVE A WORKING LOAD LIMIT THAT IS EQUAL TO OR GREATER THAN THE COMBINED WEIGHT OF INTENDED LOAD PLUS THE CUSTOM TOMBSTONE LIFTER.**
  3. **UNDER NO CIRCUMSTANCES SHOULD ANY COMPONENT USED AS RIGGING TO THE CUSTOM TOMBSTONE LIFTER BE OF A RATED CAPACITY LESS THAN THAT OF THE CUSTOM TOMBSTONE LIFTER.**



170 State Route 271  
Ligonier, PA 15658  
1-800-653-6069

4. **DO NOT RIG UNPROTECTED NYLON SLINGS OR WIRE ROPE DIRECTLY THROUGH LIFT BAIL.**
  
5. **IF USING EQUIPMENT OTHER THAN A CRANE: USE RIGGING OF SUFFICIENT LENGTH TO PREVENT CONTACT BETWEEN CUSTOM TOMBSTONE LIFTER AND EQUIPMENT.**

## Section V. Operation.



Before attempting to use the Custom Tombstone Lifter device **ALWAYS** perform a test lift on the intended object(s) to confirm proper operation. **DO NOT** use a Custom Tombstone Lifter to handle objects beyond the rated capacity or range.



Manipulation of the Custom Tombstone lifter by ground personnel for the purpose of alignment with load shall only be done with Custom Tombstone lifter suspended above the block. **KEEP ALL HANDS AWAY FROM THE CUSTOM TOMBSTONE LIFTER DURING OPERATION.**

### A. Automatic operation:

1. Ensure that the Custom Tombstone Lifter's capacity and range are appropriate to the block to be handled.
2. Position Custom Tombstone Lifter at or near center of object to be lifted.
3. Lower Custom Tombstone Lifter onto object, taking care to minimize impact.
4. Ensure that all persons are clear of Custom Tombstone Lifter and Block.
5. Release tension on lift cable to cycle the actuator.
6. Raise Custom Tombstone Lifter and load in a smooth motion. Do not "jerk".
7. Deposit at desired location.
8. Release tension on lift cable to cycle the actuator. (Note: avoid undue slamming of the Custom Tombstone Lifter into open position to prolong actuator life.)
9. Remove Custom Tombstone Lifter (Custom Tombstone Lift is latched in open position automatically)

*Tip: The majority of wear on the Custom Tombstone lifter and associated components results from shock loading, impacting, and poor alignment of the Custom Tombstone lifter with the load. Minimizing these incidents will greatly extend the life of the Custom Tombstone lifter and consumables.*

**B. Avoid Jarring, swinging, and otherwise unnecessary manipulation of the load.**

**C. Avoid handling of loads off center.**

**D. DO NOT USE THE CUSTOM TOMBSTONE LIFTER TO PICK MULTIPLES OF ITEMS IN A SINGLE PICK.**



170 State Route 271  
Ligonier, PA 15658  
1-800-653-6069

E. Observe all safety practices associated with operation of hoist machinery.

F. DO NOT USE CUSTOM TOMBSTONE LIFTER TO DRAG LOADS.

G. DO NOT ALLOW LOAD (BLOCK) TO CONTACT ANY SURFACE/OBJECT WHILE BEING HANDLED.



*The Custom Tombstone Lifter handling device produces grip **proportional to and dependent on** the weight of the load. It is for this reason that while in operation the Custom Tombstone Lifter and load **NEVER** be allowed to contact other items.*





## Section VI. Maintenance

### A. Daily:

1. Visually inspect Custom Tombstone Lifter for signs of stress and wear.
2. Check that bolts and nuts are snug.
3. Check that key-way area of the attachment and lift body are properly seated.
4. Ensure free movement of all components.
5. Ensure that all warning labels are present and readable.
6. Check that the actuator mounting screws are snug and seated.
7. Lubricate all moving mechanisms with penetrating oil.
8. **LUBRICATE ACTUATOR WITH LIGHT PENETRATING OIL ONLY (WD40™)**

### B. Annually\*

1. Remove pivot bolts and coat with grease.
2. Inspect holes, pins, bolts etc. for wear. See sect VII for criteria.
3. Remove actuator, clean and lubricate with light penetrating oil – check for signs of wear, replace if necessary.

\* *Frequency depends on usage, environmental conditions, etc.*

## Section VII. Inspection Criteria

**THE CUSTOM TOMBSTONE LIFTER UNIT AND ALL OF ITS ASSOCIATED COMPONENTS SHALL BE REMOVED FROM SERVICE AND TAGGED APPROPRIATELY UNTIL RECERTIFICATION BY A QUALIFIED INDIVIDUAL IN ANY OF THE FOLLOWING CONDITIONS:**

### A. General

1. Cracking in any component or member.
2. Cracking in any weld.
3. Visible distortion in any member.
4. Visible distortion in any Bolt/Pin/Shaft.

### B. Specific

#### 1. Lift Bail

- a. The lift bail shall be replaced if a 20% loss in cross-sectional area from the original member(s) can be demonstrated. Note: cross section of welds, “mushroomed” wear faces, and burrs are not accounted for as cross-sectional area. (See ill.)

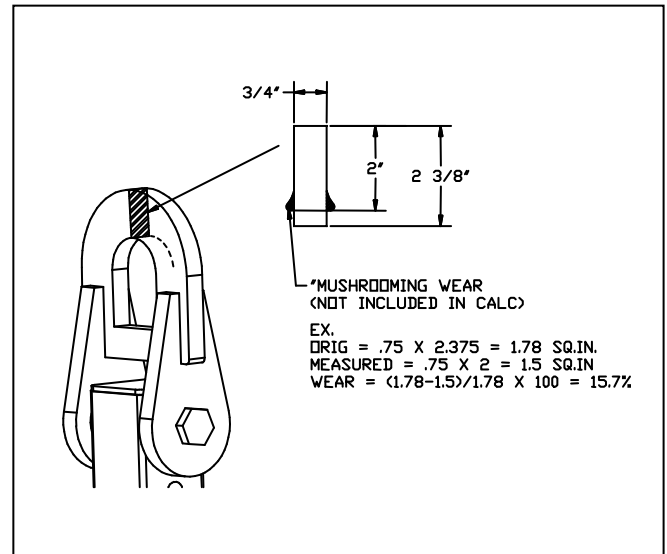

#### 2. Holes.

- a. Any members through which bolted or pinned connections pass shall be replaced if a 10% loss in cross-sectional area from the original member(s) can be demonstrated. Note: cross section of welds, “mushroomed” wear faces, and burrs are not accounted for as cross-sectional area.

#### 3. Pins/Bolts.

- a. Any visible deformation of a pin, shaft or bolt shall require replacement of that part.

#### 4. Pads – Replace if:

- a. For units utilizing urethane gripping pads, if surface of any given mounting bolt is not at least 3/32” below the surface of the pad,.
- b. Any de-lamination of the pad from the backing plate.
- c. Any scarring, chunking, or missing pad material constituting a total combined loss of surface area greater than 3 sq. in. per pad.
- d. Any single scar, chunk, or missing pad face that is greater than 1 sq. in per pad.

## Section VIII. Parts/Drawings

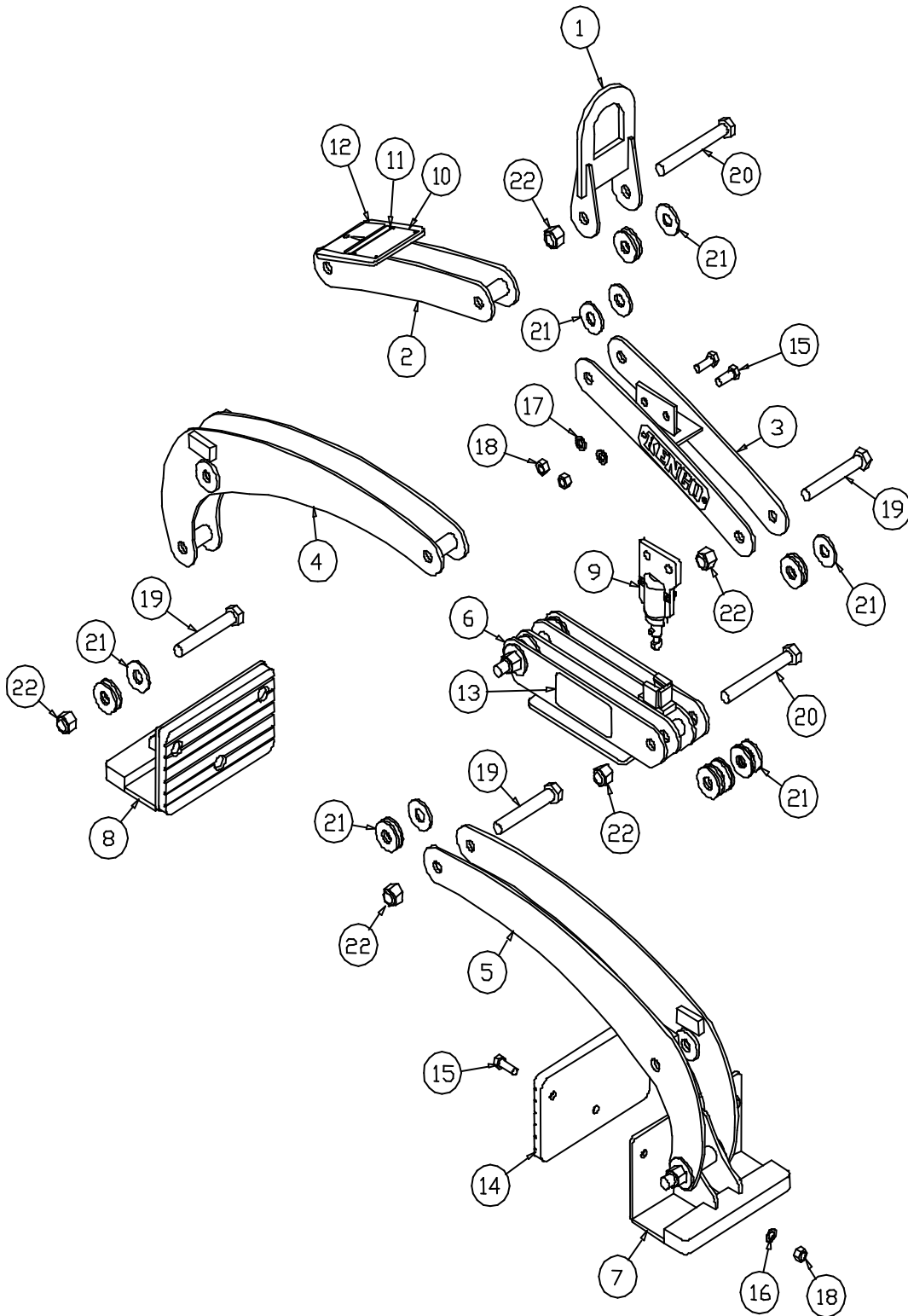

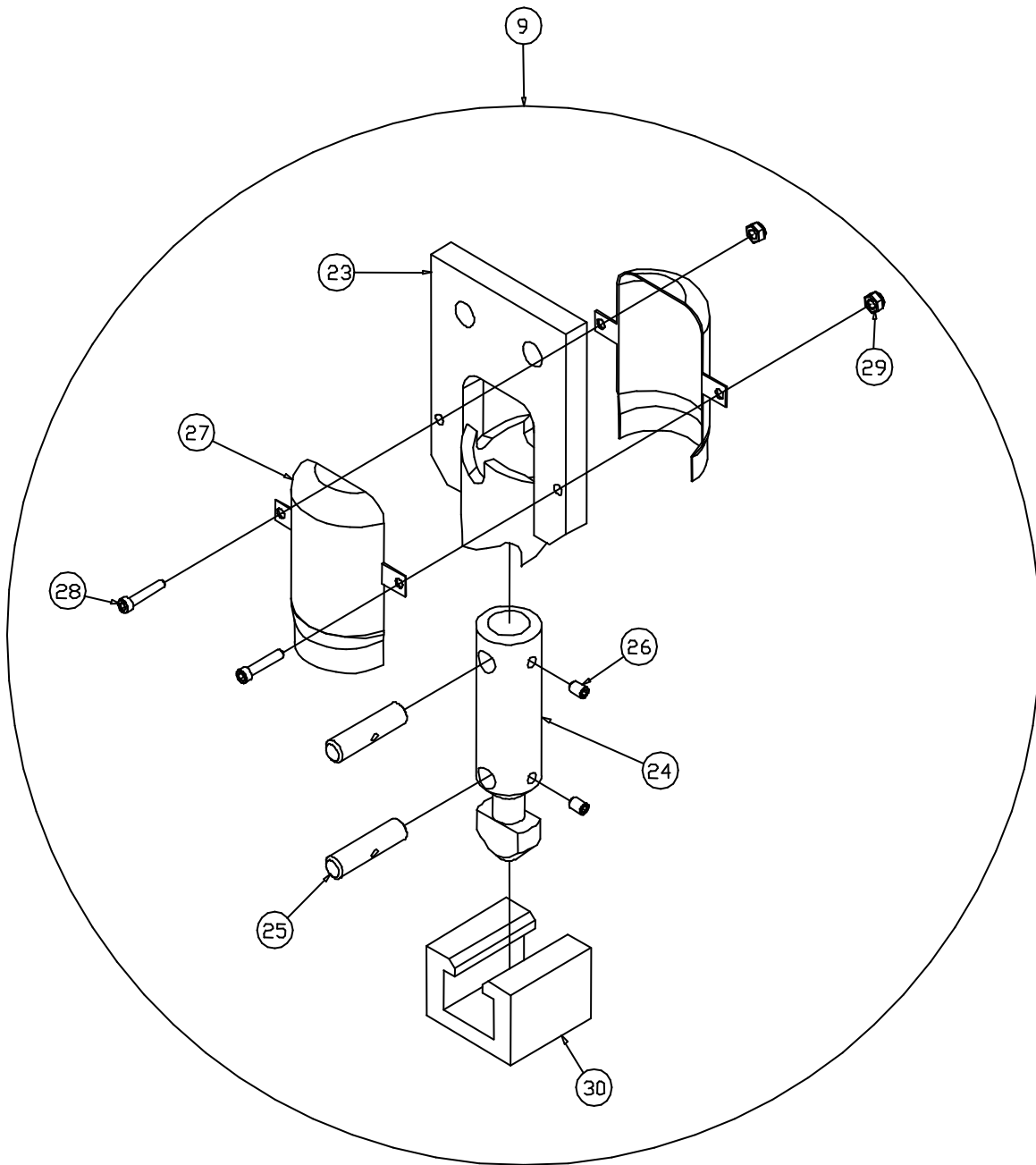



10

<b>KENCO CORPORATION</b>	
<b>877-4ATTACH</b>	
MODEL	<input type="text"/>
USAGE	<input type="text"/>
CAPACITY	<input type="text"/> WT. <input type="text"/>
SERIAL NO.	<input type="text"/>

11

THIS LIFTER IS DESIGNED TO ASME BTH-1	
DESIGN CATEGORY <input type="text"/>	SERVICE CLASS <input type="text"/>

12

 <b>WARNING</b>	
	<p>Read and understand operator's manual before using this equipment.</p> <p>Failure to follow operating and maintenance procedures could result in death or serious injury.</p>

13

<p><b>DANGER</b></p> <p><b>DO NOT STAND UNDER OR NEAR</b></p> <p><b>WHILE MACHINE IS OPERATING</b></p>
--



NOTE: MODEL AND SERIAL NUMBER OF LIFTER MUST ACCOMPANY PART ORDERS.

Item Number	Quantity	Part Name
1	1	TSL15C3T12 LIFTEYE ASSY.
2	1	TSL15C3T12 NARROW ARM ASSY.
3	1	TSL15C3T12 WIDE ARM ASSY.
4	1	TSL15C3T12 NARROW LEG ASSY.
5	1	TSL15C3T12 WIDE LEG ASSY.
6	1	TSL15C3T12 CENTER LINK ASSY.
7	1	TSL15C3T12 NARROW PAD ASSY.
8	1	TSL15C3T12 WIDE PAD ASSY.
9	1	SMALL ACTUATOR
10	1	KENCO ID TAG
11	1	BTH TAG
12	1	SMALL WARNING STICKER
13	2	DANGER STICKER
14	2	MI125 PAD
15	8	.5 X 1.25 CAPSCREW
16	6	.5 INTERNAL LOCK WASHER
17	2	.5 LOCK WASHER
18	8	.5 NUT
19	4	.75 X 5 CAPSCREW
20	3	.75 X 6 CAPSCREW
21	31	.75 FLAT WASHER
22	7	.75 NYLOCK NUT
23	1	SMALL ACTUATOR BODY
24	1	SMALL ACTUATOR SHAFT
25	2	SMALL ACTUATOR PIN
26	2	SMALL ACTUATOR SET SCREW
27	2	SMALL ACTUATOR COVER
28	2	SMALL ACTUATOR COVER SCREW
29	2	SMALL ACTUATOR COVER NUT
30	1	SMALL RECEIVER BLOCK



## **Section IX.      Warranty**

### **A. Policy**

1. KENCO Corporation (KENCO) warrants the Kenco Custom Tombstone Lifter lifting device (not including pads or consumable items) sold by KENCO to be free from proven defects in material and workmanship for a period of six (6) months from the delivery date to the original customer.
2. Warranty is limited to replacement of parts and/or assemblies, which upon inspection by KENCO are deemed to be defective in material, workmanship, or both.
3. Warranty shall not extend to products that have been altered or repaired in any way without the express written consent of KENCO.
4. Warranty shall not extend to any product that has been misused, abused, or improperly applied or any defect resulting thereof.
5. Defects and corrosion that are the result of improper storage and/or maintenance are not warrantable.
6. Wear items such as Pads, Pins or Lifting bails etc. are not considered for warranty claims.

### **B. Disclaimer**

1. THIS WARRANTY IS EXCLUSIVE AND IN LIEU OF ALL OTHER REPRESENTATIONS AND WARRANTIES EXPRESSED OR IMPLIED, AND KENCO EXPLICITLY DISCLAIMS AND EXCLUDES ANY IMPLIED WARRANTY OF MERCHANTABILITY FOR A PARTICULAR PURPOSE. IN NO EVENT SHALL THE END USER BE ENTITLED TO ANY CONSEQUENTIAL, INCIDENTAL OR CONTINGENT DAMAGES OF ANY KIND ARISING OUT OF BREACH OF CONTRACT, WARRANTY (INCLUDING NEGLIGENCE AND STRICT LIABILITY) OR OTHER THEORIES OF LAW, WITH RESPECT TO PRODUCTS SOLD OR SERVICES RENDERED BY KENCO, OR ANY UNDERTAKINGS, ACTS OR OMISSIONS RELATING THERETO.